

HDPE 100 FITTINGS

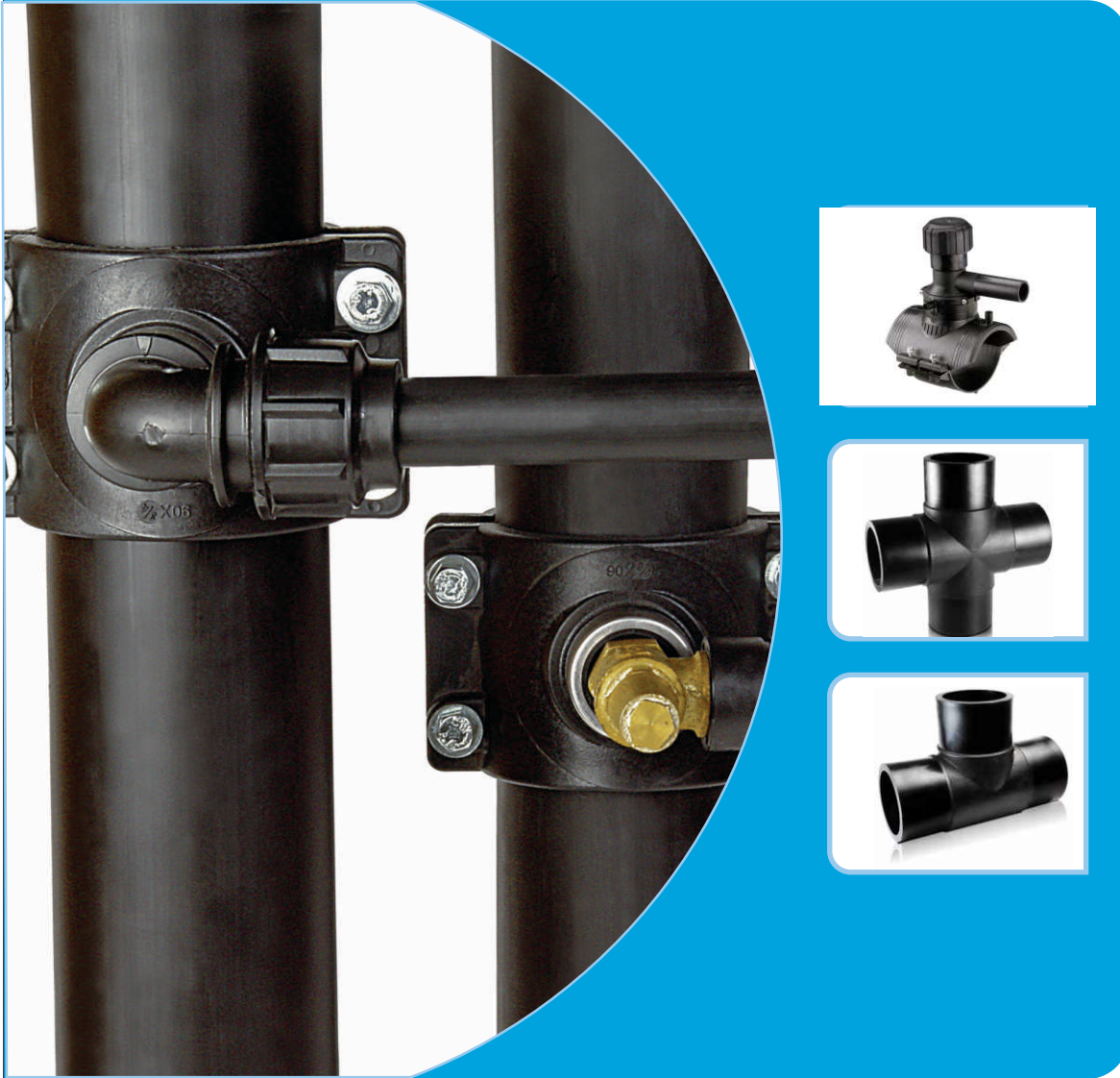

H
D
P
E

DADEX



The Dadex PE100 Pipe and Fittings System is a versatile, fast and durable high-density polyethylene supply system for Industrial and Commercial plumbing applications. The high-pressure pipe and fittings provide a reliable solution to the challenges presented by modern supply systems and is available in a large range of sizes.

Dadex provides a complete range of fittings for its Polyethylene (PE) pipes, manufactured in different diameters and grades. These fittings are manufactured as per international standards to provide leak free and reliable jointing system. These fittings are either compression type or Butt fused type depending upon the diameter of pipes. Butt fused fittings are further sub-divided into Injection moulded and Fabricated type. Fittings are compatible with polyethylene pipes manufactured as per ISO4427 & DIN 8074/75.

Fittings are continuously monitored throughout the entire production process in accordance with the internal testing programs in compliance with the standards EN 1555, EN 12201, ISO 4427.

The barcode label applied on the electrofusion fittings contain the welding parameter according to standard. ISO 13950 and the traceability data of the fitting according to standard ISO 12176-4.

It's very important to control thermal movement and the temperature and pressure relationship within a pressure system.

The Dadex T-flex PE100 System utilises the benefits of polyethylene jointing technologies and excellent chemical resistance which means it can be used across a wide range of applications including:

- Water supply and distribution
- Water treatment
- Cooling water
- Pressurised waste water systems
- Transportation of chemicals

Due to the fine surface structure, injection moulded PE fittings are ideal for transporting gases and liquids. The excellent UV resistance offers the possibility for outside installation without further need for additional protection effort.

Material

Polyethylene (PE100) classified according to minimum long-term strength (MRS), Colour black.

Geometric Properties

Outside diameter and wall thickness according to EN 1555 and EN 12201.

Tolerances of z-sizes depend on the dimension. Up to d/D 160 = +/-3 mm and from d/D 180= +/- 10 mm.

Features & Benefits

- Fast and easy installation
- Light weight
- Superior flow characteristics
- Operating temperature -40°C to +60°C (subject to pressure requirement)
- Comprehensive system includes full range of pipes and fittings
- Excellent UV & abrasion resistance
- Fusion weld or mechanical installation
- Excellent impact resistance
- Excellent corrosion, biological and chemical resistance
- Used extensively worldwide
- Prefabrication service is available

Joining Technology

- Butt-Welding
- Electro fusion socket-welding
- Flange connection

Injection Moulded Equal Tee 90°

Nominal size (dn) (mm)	Code	Z (mm)	Z1 (mm)	L (mm)
*20	TE1C01	143	74	41
*25	TE1C02	158	78	41
32	TE1C03	166	82	45
40	TE1C04	188	96	50
50	TE1C05	210	107	50.5
63	TE1C06	219	115	66
75	TE1C07	246	129	71
90	TE1C08	271	143	70
110	TE1C09	318	167	85
125	TE1C10	335	168	90
*140	TE1C11	393	192	92
160	TE1C12	400	200	101
180	TE1C13	465	233	106
200	TE1C14	448	239	108
225	TE1C15	454	262	102
250	TE1C16	517	282	100
280	TE1C17	600	323	94
315	TE1C18	595	298	92
355	TE1C19	650	325	121
400	TE1C20	645	325	100
450	TE1C21	970	510	200
500	TE1C22	970	510	200

o Producing up to size 315 mm with SDR 9 and SDR 7.4
* Future Products

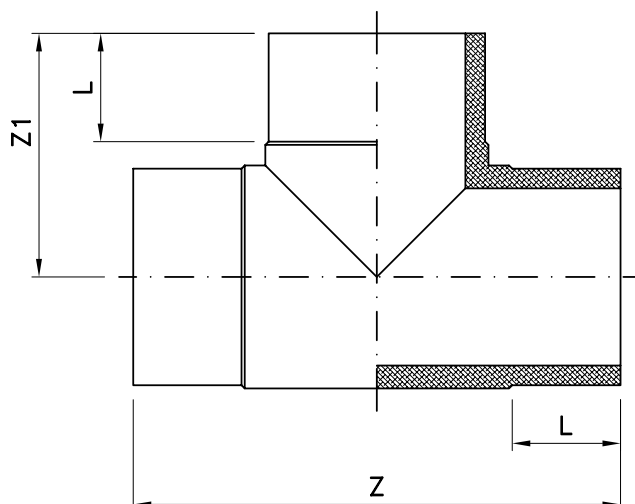
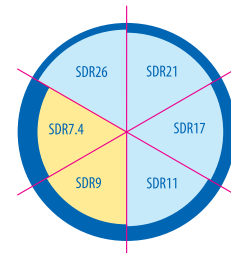

Injection Moulded Reduced Tee 90°

Nominal size (mm)	Code	L1 (mm)	L2 (mm)	Z1 (mm)	Z2 (mm)
63×40	TE4C0604	66	49	217	105
63×50	TE4C0605	67	63	220	109
75×40	TE4C0704	72	50	249	119
75×50	TE4C0705	71	63	246	121
75×63	TE4C0706	72	66	250	126
90×63	TE4C0806	71	67	271	133
90×75	TE4C0807	69	70	267	128
110×63	TE4C0906	87	66	318	168
110×75	TE4C0907	81	72	320	159
110×90	TE4C0908	86	80	318	155
125×63	TE4C1006	89	66	336	166
125×75	TE4C1007	89	71	337	167
125×90	TE4C1008	89	81	332	163
125×110	TE4C1009	90	86	340	168
160×63	TE4C1206	102	67	404	197
160×75	TE4C1207	98	75	400	195
160×90	TE4C1208	101	83	398	201
160×110	TE4C1209	102	88	405	204
200×63	TE4C1406	116	72	440	220
200×75	TE4C1407	115	72	440	220
200×90	TE4C1408	117	83	448	228
200×110	TE4C1409	104	79	435	215

Nominal size (mm)	Code	L1 (mm)	L2 (mm)	Z1 (mm)	Z2 (mm)
200×160	TE4C1412	116	90	450	214
250×90	TE4C1608	103	79	515	267
250×110	TE4C1609	102	87	515	270
250×125	TE4C1610	101	95	515	268
250×160	TE4C1612	102	103	515	270
250×200	TE4C1614	100	101	515	268
315×90	TE4C1608	92	92	595	296
315×110	TE4C1809	92	92	595	296
315×125	TE4C1810	92	92	595	296
315×160	TE4C1812	87	87	580	289
315×200	TE4C1814	91	95	590	301
315×250	TE4C1816	91	103	585	296
355×110	TE4C1909	118	87	640	290
355×160	TE4C1912	118	102	640	307
355×200	TE4C1914	119	119	644	332
355×250	TE4C1916	120	113	645	324
400×160	TE4C2012	98	100	645	335
400×200	TE4C2014	99	102	643	337
400×250	TE4C2016	98	100	650	330

◊ Producing up to size 315mm with SDR9 and SDR 7.4
- Other branches with make by Reducer.

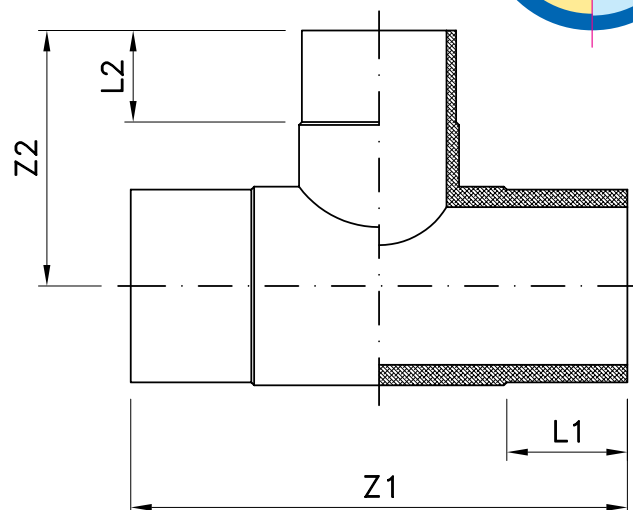
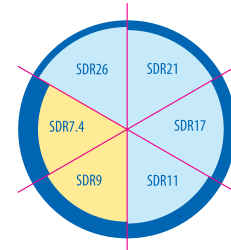

Injection Moulded Elbow 90°

Nominal size (mm)	Code	Z (mm)	L (mm)
*20	EL3C01	63	41
*25	EL3C02	63	41
32	EL3C03	72	45
40	EL3C04	80	50
50	EL3C05	110	60
63	EL3C06	112	61
75	EL3C07	120	60
90	EL3C08	127	55
110	EL3C09	153	84
125	EL3C10	172	85
160	EL3C12	200	102
180	EL3C13	245	126
200	EL3C14	248	117
225	EL3C15	243	111
250	EL3C16	250	95
315	EL3C18	329	120
355	EL3C19	325	118
400	EL3C20	376	120
450	EL3C21	380	120
500	EL3C22	390	120

◊ Producing up to size 315 mm with SDR 9 and SDR 7.4

* Future Products

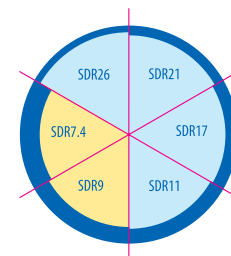
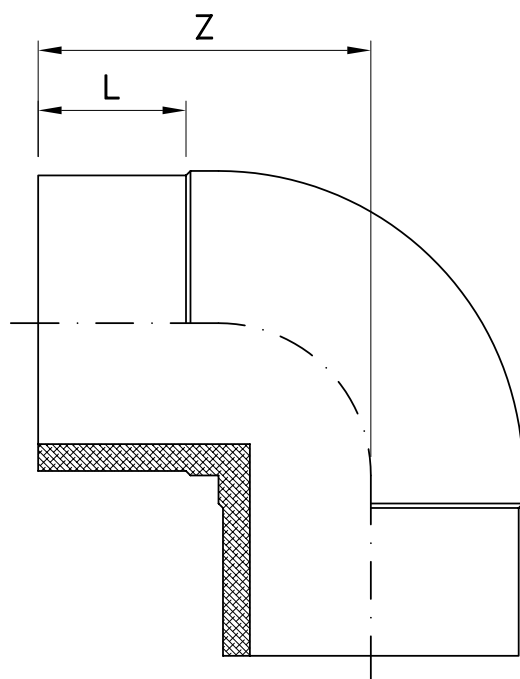

Injection Moulded Elbow 45°

Nominal size (mm)	Code	Z (mm)	L (mm)
*25	EL1C02	63	41
*32	EL1C03	72	44
*40	EL1C04	80	49
50	EL1C05	92	58
63	EL1C06	94	58
75	EL1C07	105	60
90	EL1C08	120	79
110	EL1C09	121	85
125	EL1C10	130	88
160	EL1C12	148	85
180	EL1C13	166	106
200	EL1C14	180	117
225	EL1C15	184	111
250	EL1C16	210	128
315	EL1C18	206	102
*355	EL1C19	200	120
400	EL1C20	222	118

⚠ Producing up to size 315 mm with SDR 9 and SDR 7.4

*Future Products

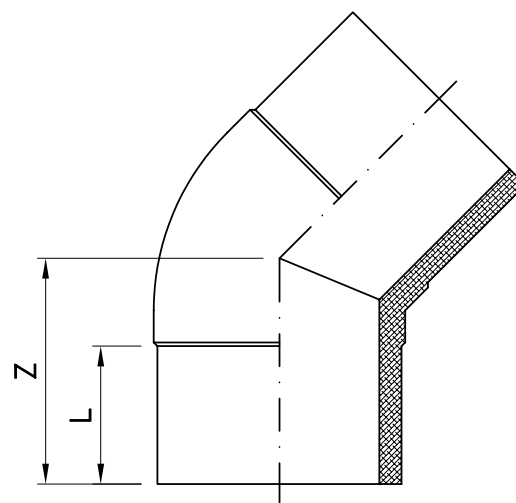
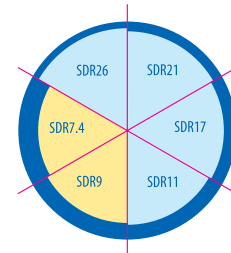

Injection Moulded Concentric Reducer long spigot

Nominal size (mm)	Code	L1 (mm)	L (mm)	Lt (mm)
*40×32	RE1C0403	45	50	125
50×25	RE1C0502	48	59	134
50×32	RE1C0503	33	56	122
50×40	RE1C0504	35	56	125
63×32	RE1C0603	39	59	131
63×40	RE1C0604	49	56	132
63×50	RE1C0605	59	51	127
75×50	RE1C0705	57	66	148
75×63	RE1C0706	62	68	144
90×63	RE1C0806	51	69	139
90×75	RE1C0807	66	69	152
110×20	RE1C0901	41	77	154
110×32	RE1C0903	41	77	154
110×63	RE1C0906	54	80	168
110×75	RE1C0907	54	77	167
110×90	RE1C0908	64	82	167
125×90	RE1C1008	73	91	210
125×110	RE1C1009	63	74	151
160×90	RE1C1208	87	76	212
160×110	RE1C1209	83	101	227
160×125	RE1C1210	70	94	215
200×110	RE1C1409	88	101	248
200×160	RE1C1412	86	132	283
250×110	RE1C1609	85	120	285
250×160	RE1C1612	96	121	294
250×200	RE1C1614	88	122	287
*315×250	RE1C1816	135	88	300
500×400	RE1C2220	100	100	380
500×450	RE1C2221			
560×400	RE1C2320			
560×450	RE1C2321			
560×500	RE1C2322			
630×400	RE1C2420			
630×450	RE1C2421			
630×500	RE1C2422			
630×560	RE1C2423			

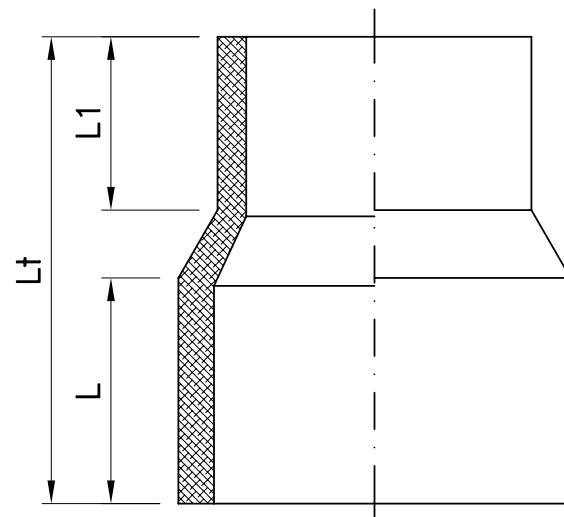
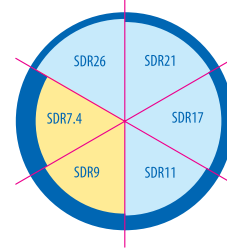

◊ Producing up to size 315 mm with SDR 9 and SDR 7.4
*Future Products

Injection Moulded Cap

Nominal size (mm)	Code	Z (mm)	L (mm)
*25	CA1C02	50	40
*32	CA1C03	50	40
40	CA1C04	63	57
50	CA1C05	63	57
63	CA1C06	65	52
75	CA1C07	78	57
90	CA1C08	88	65
110	CA1C09	91	68
125	CA1C10	100	79
160	CA1C12	122	88
200	CA1C14	135	114
*250	CA1C16	205	120
*315	CA1C18	225	150

◊ Producing up to size 315 mm with SDR 9 and SDR 7.4
 * Future Products

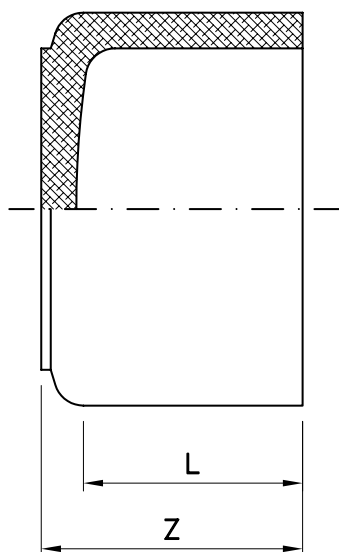
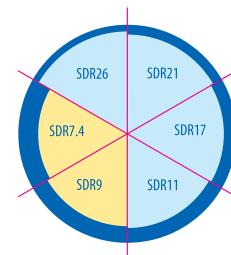

Injection Moulded Flange Adaptor-Type B

Nominal size (mm)	Code		h1 (mm)		d2 (mm)	d3 (mm)	d4 (mm)	Z (mm)	
	Normal	Long	PN10	PN16				Normal	Long
40	FL2C04	FL4C04	11	11	78	50	-	81	85
50	FL2C05	FL4C05	12	12	88	75	-	83	85
63	FL2C06	FL4C06	14	14	102	75	-	92	95
75	FL2C07	FL4C07	16	16	122	89	66	111	125
90	FL2C08	FL4C08	17	17	138	105	78	120	140
110	FL2C09	FL4C09	18	18	158	125	100	127	160
125	FL2C10	FL4C10	18	25	158	132	114	121	170
140	FL2C11	FL4C11	18	25	188	155	127	153	200
160	FL2C12	FL4C12	18	25	212	175	151	164	200
180	FL2C13	FL4C13	20	30	212	180	158	171	200
200	FL2C14	FL4C14	24	32	268	232	203	180	200
225	FL2C15	FL4C15	24	32	268	235	210	193	200
250	FL2C16	-	25	35	320	285	245	200	-
280	FL2C17	-	25	35	320	291	265	200	-
315	FL2C18	-	25	35	370	335	300	222	-
355	FL2C19	-	30	40	430	373	340	178	-
400	FL2C20	-	33	46	482	427	385	154	-
450	FL2C21	-	46	60	585	514	400	160	-
500	FL2C22	-	46	60	585	530	440	170	-
560	FL2C23	-	50	60	685	615	490	178	-
630	FL2C24	-	50	60	685	642	545	154	-
710	FL2C25	-	50	-	800	730	-	300	-
800	FL2C26	-	52	-	900	840	-	300	-
900	FL2C27	-	55	-	1005	944	-	300	-
1000	FL2C28	-	60	-	1110	1047	-	300	-

Could be weld with electrofusion coupler
Type B: With chamfer suitable for butterfly valve .

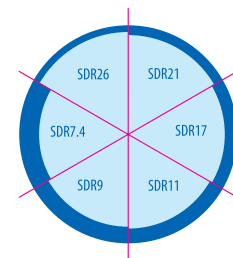
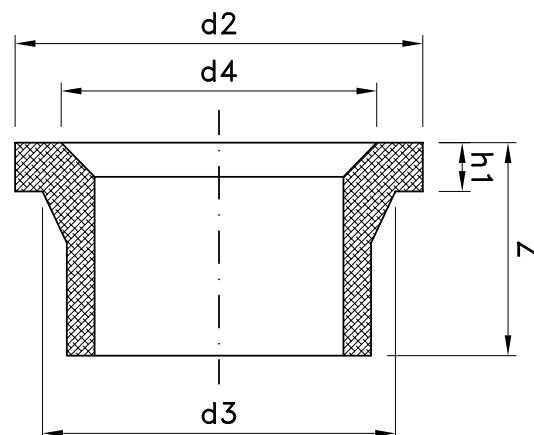

Injection Moulded Cross 90°

Nominal size (mm)	Code	Zk (mm)	Le (mm)
90	CR1C08	149	80
110	CR1C09	165	85
* 125	CR1C10	175	85
160	CR1C12	206	100
200	CR1C14	245	118
250	CR1C16	303	144
* 315	CR1C18	330	155

ð Producing up to size 315 mm with SDR 9 and SDR 7.4
 * Future Products

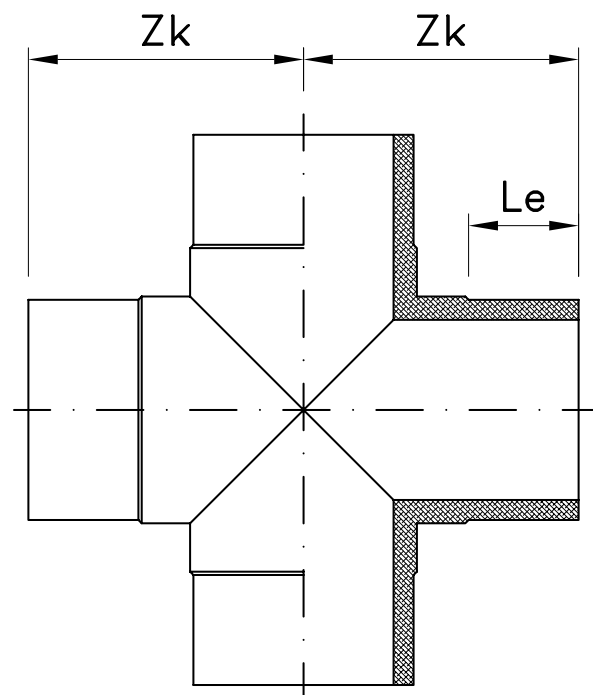
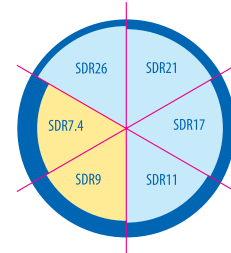

Flanged Fittings

Flat Face Flanged Equal Tee 90°

Nominal size (mm)	Code	D (mm)	P (mm)	Z1 (mm)	Z (mm)	T ±2 (mm)	Bolt Number
90	TE6C08	200	160	148	309	20	8
110	TE6C09	215	180	165	360	20	8
125	TE6C10	245	180	214	430	20	8
160	TE6C12	280	240	247	500	20	8
200	TE6C14	342	295	300	595	22	8
250	TE6C16	395	350	295	600	26	12
315	TE6C18	445	400	171	595	30	12

PN4 bar and 6 bar : without backing ring

ò PN10 bar : With backing ring

ò PN16 & 10 bar : Using steel core hole flange

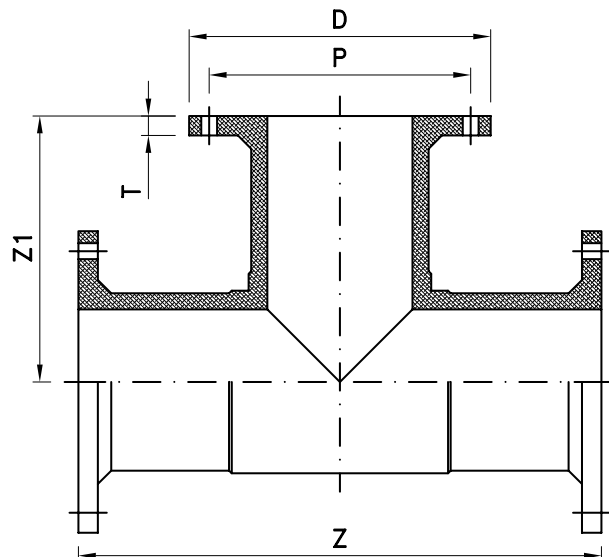
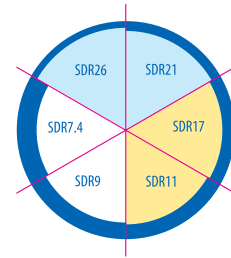

Flanged Fittings

Flat Face Flanged Reduced Tee 90°

Nominal size (mm)	Code	D1 (mm)	D2 (mm)	P1 (mm)	P2 (mm)	Z1 (mm)	Z2 (mm)	T1 ±2 (mm)	T2 ±2 (mm)	Bolt Number
110×75	TE7C0907	217	183	180	145	360	174	20	18	8-4
110×90	TE7C0908	218	195	180	160	360	172	22	22	8-8
160×75	TE7C1207	278	183	240	145	495	248	22	18	8-4
160×90	TE7C1208	278	195	240	160	495	248	22	22	8-8
160×110	TE7C1209	278	218	240	180	495	248	22	20	8-8
200×90	TE7C1408	335	195	295	160	593	303	22	20	8-8
200×110	TE7C1409	340	219	295	180	590	301	22	20	8-8
200×160	TE7C1412	340	278	295	240	590	301	22	22	8-8
250×90	TE7C1608	395	200	350	160	600	300	26	20	12-8
250×110	TE7C1609	395	218	350	180	600	300	26	20	12-8
250×160	TE7C1612	395	282	350	240	585	295	28	22	12-8
315×90	TE7C1808	444	200	400	160	595	300	30	22	12-8
315×110	TE7C1809	444	218	400	180	595	300	30	22	12-8
315×160	TE7C1812	444	280	400	240	600	302	30	24	12-8
315×200	TE7C1814	444	338	400	295	595	300	30	26	12-8

PN4 bar and 6 bar : without backing ring

◦ PN10 bar : With backing ring

◦ PN16 & 10 bar : Using steel core hole flange

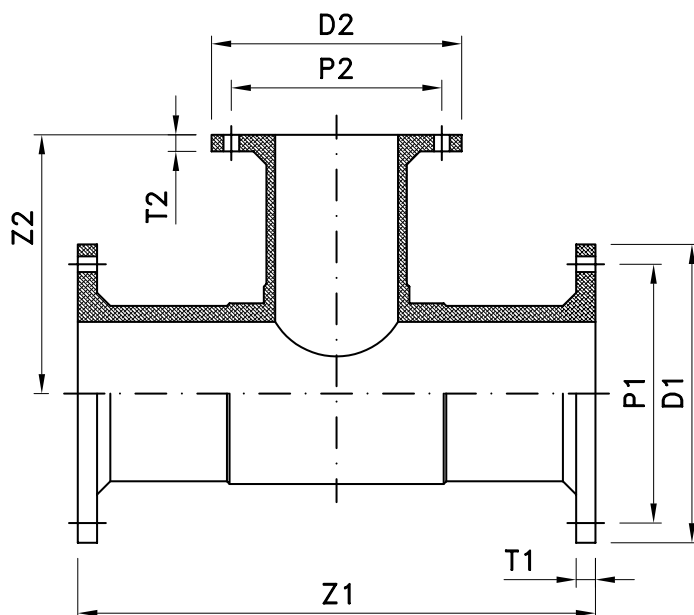
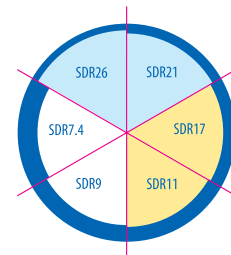

Flanged Fittings Flat Face Flanged Elbow 90°

Nominal size (mm)	Code	D (mm)	P (mm)	Z (mm)	T±2 (mm)	Bolt Number
90	EL6C08	200	160	152	18	8
110	EL6C09	215	180	183	20	8
125	EL6C10	243	180	218	20	8
160	EL6C12	280	240	300	22	8
200	EL6C14	340	295	280	22	8
250	EL6C16	395	350	300	24	12
315	EL6C18	445	400	300	28	12

PN4 bar and 6 bar : without backing ring

ò PN10 bar : With backing ring

ò PN16 & 10 bar : Using steel core hole flange

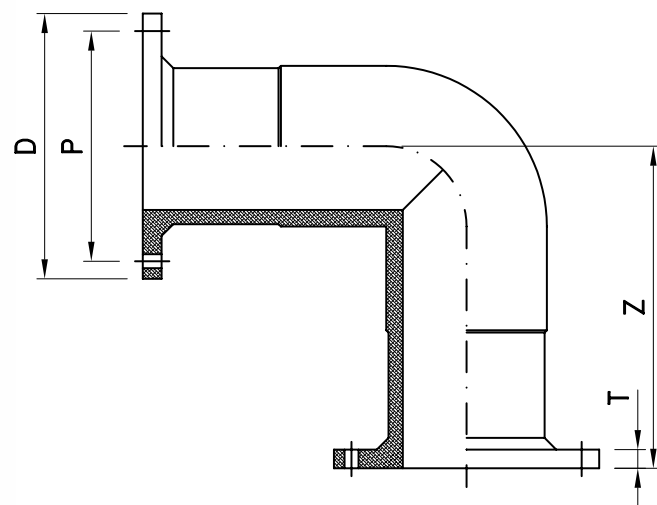
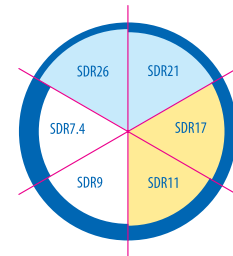

Backing Ring PP/Steel Backing Ring

Flange Size (mm)	Code	D (mm)	d3 (mm)	K (mm)	d2 (mm)	Bolt Number	Bolt Size	T±1.5 (mm)
63	RI1C06	165	78	125	18	4	M 16	18
75	RI1C07	185	92	145	18	4	M 16	18
90	RI1C08	201	108	160	18	8	M 16	20
110	RI1C09	221	130	180	18	8	M 16	20
125	RI1C10	251	135	180	18	8	M 16	20
160	RI1C12	286	177	240	22	8	M 20	24
200	RI1C14	340	235	295	22	8	M 20	24
225	RI1C15	340	238	295	22	8	M 20	24
250	RI1C16	409	288	350	22	12	M 20	30
315	RI1C18	463	338	400	22	12	M 20	34
* 355	RI1C19	520	376	470	26	16	M20	40
* 400	RI1C20	580	430	525	30	16	M24	40

◊ Possible To use For PN6 & PN10 .

Ring Steel : DIN2501

* Future Products

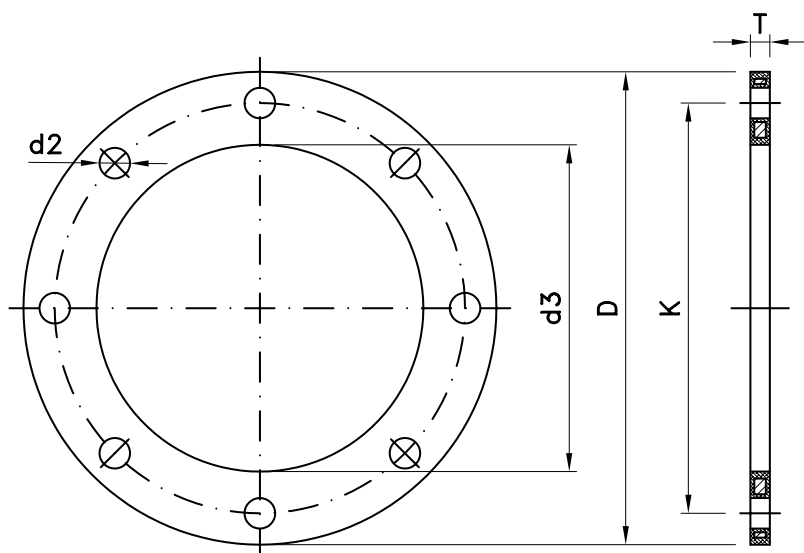
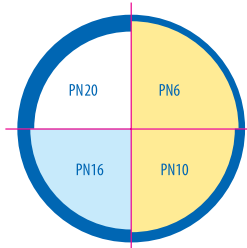

Backing Ring Backing Ring (EN 1092 - 2013) - PN16

DN	Pipe Outside (mm)	Code	D (mm)	K (mm)	d2 (mm)	Bolting	
						Number	Size
20	25	RI5S02	105	75	14	4	M12
25	32	RI5S03	115	85	14	4	M12
32	40	RI5S04	140	100	18	4	M16
40	50	RI5S05	150	110	18	4	M16
50	63	RI5S06	165	125	18	4	M16
65	75	RI5S07	185	145	18	8	M16
80	90	RI5S08	200	160	18	8	M16
100	110	RI5S09	220	180	18	8	M16
100	125	RI5S10	220	180	18	8	M16
125	140	RI5S11	250	210	18	8	M16
150	160	RI5S12	285	240	22	8	M20
150	180	RI5S13	285	240	22	8	M20
200	200	RI5S14	340	295	22	12	M20
200	225	RI5S15	340	295	22	12	M20
250	250	RI5S16	405	355	26	12	M24
250	280	RI5S17	405	355	26	12	M24
300	315	RI5S18	460	410	26	12	M24
350	355	RI5S19	520	470	26	16	M24
400	400	RI5S20	580	525	30	16	M27
450	450	RI5S21	640	585	30	20	M27
500	500	RI5S22	715	650	33	20	M30
600	630	RI5S24	840	770	36	20	M33

Note :Thickness According to Customer Order

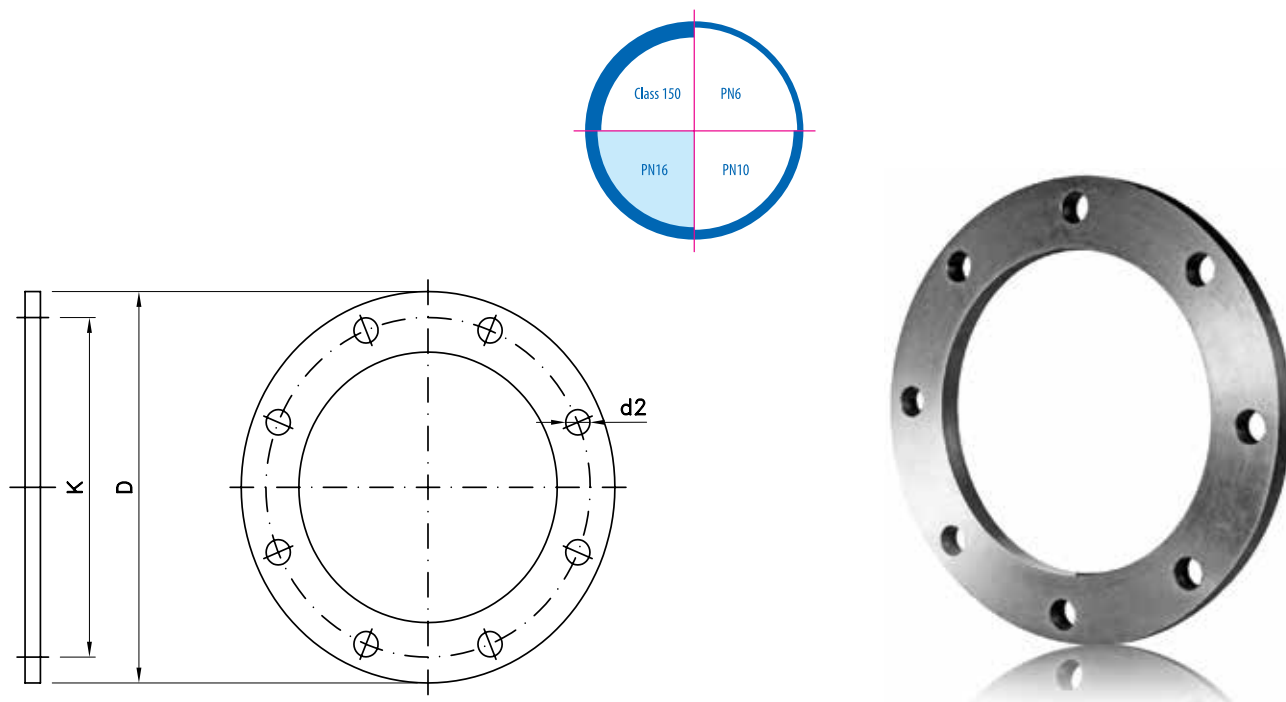

Gasket

Pipe Outside Diameter (mm)	Code	d10 Outside of Gasket (mm)	Pipe Series (Inside Of Gasket) d9 (mm)				b (mm)
			2	3	4	5	
20	GS1E01	45	-	-	-	16	2
25	GS1E02	58	-	-	21	20	2
32	GS1E03	68	-	-	28	26	2
40	GS1E04	78	-	36	35	33	2
50	GS1E05	88	-	46	44	41	2
63	GS1E06	102	59	58	56	51	2
75	GS1E07	122	70	69	66	61	2
90	GS1E08	138	84	83	80	74	2
110	GS1E09	158	103	101	97	90	3
125	GS1E10	158	117	115	111	102	3
140	GS1E11	188	131	129	124	114	3
160	GS1E12	212	150	148	142	131	3
180	GS1E13	212	169	166	160	147	3
200	GS1E14	268	188	185	177	164	3
225	GS1E15	268	211	208	199	184	3
250	GS1E16	320	234	231	222	204	3
280	GS1E17	320	263	258	248	229	3
315	GS1E18	370	295	291	279	258	3
355	GS1E19	430	333	328	315	290	3
400	GS1E20	482	375	369	355	327	3
450	GS1E21	585	422	415	399	368	3
500	GS1E22	585	469	461	443	409	3
560	GS1E23	685	525	517	497	456	3
630	GS1E24	685	590	581	559	513	3
710	GS1E25	800	666	655	630	-	3
800	GS1E26	905	750	738	709	-	3
900	GS1E27	1005	844	831	798	-	3
1000	GS1E28	1110	938	923	885	-	3
1200	GS1E29	1330	1126	1108	-	-	3

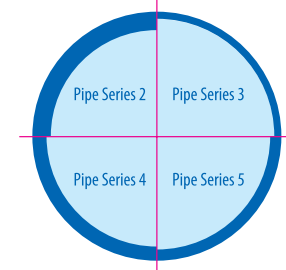

b

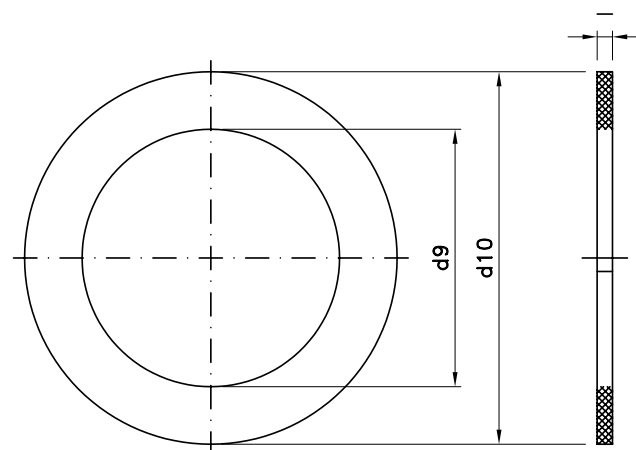
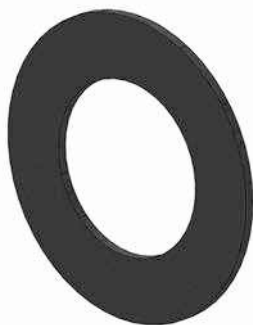

Flanged Fittings Steel Core Hole Flange

Nominal size (mm)	Code	D (mm)		P (mm)	Z (mm)	T (mm)	H (mm)		Bolt Number
		PN16	PN10				PN16	PN10	
63	FL5C06	165	165	125	82	18	18	18	4
75	FL5C07	185	185	145	100	18	18	18	8
90	FL5C08	200	200	160	106	20	18	18	8
110	FL5C09	220	220	180	112	20	18	18	8
125	FL5C10	220	220	180	124	22	18	18	8
160	FL5C12	285	285	240	132	25	22	22	8
200	FL5C14	340	340	295	140	25	22	22	12-8
250	FL5C16	405	395	350	160	30	26	22	12
315	FL5C18	460	445	400	180	35	26	22	12
*355	FL5C19	520	505	460	225	40	26	22	16
*400	FL5C20	580	565	515	240	40	30	26	16

Could be weld with electrofusion coupler.

Ring Steel : DIN2501

*Future Products

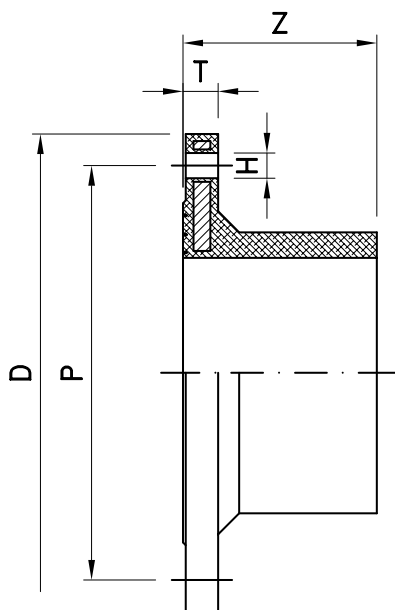
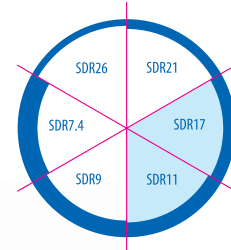

Electrofusion Fittings

Tapping saddle with 360° Rotatable outlet

Nominal size (mm)	Code	d2 (mm)	H (mm)	H1 (mm)	L (mm)	L1 (mm)	Z (mm)
63×25	SD1C0602	32	186	108	165	71	130
63×32	SD1C0603	32	186	108	165	76	130
63×40	SD1C0604	32	186	108	165	81	137
63×50	SD1C0605	32	186	108	165	86	137
63×63	SD1C0606	32	134	112	165	100	160
90×25	SD1C0802	32	199	121	165	71	130
90×32	SD1C0803	32	199	121	165	76	130
90×40	SD1C0804	32	199	121	165	81	137
90×50	SD1C0805	32	199	121	165	86	137
90×63	SD1C0806	32	248	126	165	100	160
110×25	SD1C0902	32	209	131	165	71	130
110×32	SD1C0903	32	209	131	165	76	130
110×40	SD1C0904	32	209	131	165	81	137
110×50	SD1C0905	32	209	131	165	86	137
110×63	SD1C0906	35	258	136	165	100	160
160×25	SD1C1202	32	243	156	165	71	130
160×32	SD1C1203	32	243	156	165	76	130
160×40	SD1C1204	32	243	156	165	81	137
160×50	SD1C1205	32	243	156	165	86	137
160×63	SD1C1206	35	283	161	165	100	160
200×25	SD1C1402	32	254	176	165	71	130
200×32	SD1C1403	32	254	176	165	76	130
200×40	SD1C1404	32	254	176	165	81	137
200×50	SD1C1405	32	254	176	165	86	137
200×63	SD1C1406	35	303	181	165	100	160
* 250×25	SD1C1602	32	279	201	165	76	130
* 250×32	SD1C1603	32	279	201	165	76	130
* 250×40	SD1C1604	32	279	201	165	81	137
* 250×50	SD1C1605	32	279	201	165	86	137
* 250×63	SD1C1606	35	328	206	165	100	160

* Future Products

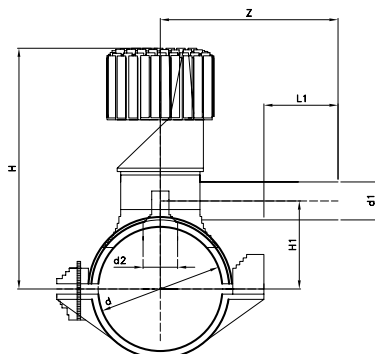
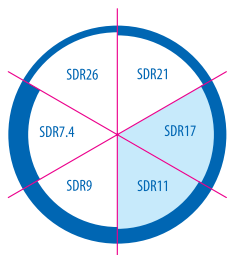

Electrofusion Fittings Electrofusion Coupler

Nominal size (dn) (mm)	Code	L (mm)	f (mm)	Z (mm)
*20	CU1C01	41	10	82
*25	CU1C02	41	10	82
*32	CU1C03	44	10	88
*40	CU1C04	49	10	98
*50	CU1C05	55	10	110
63	CU1C06	47	17	95
75	CU1C07	52	21	106
90	CU1C08	61	26	123
110	CU1C09	71	36	144
125	CU1C10	78	39	157
160	CU1C12	88	51	177
200	CU1C14	100	59	204
225	CU1C15	110	72	221
250	CU1C16	115	60	233
315	CU1C18	130	67	262
*355	CU1C19	164	42	328
*400	CU1C20	179	47	358

SDR 26, SDR 21, SDR 9 and SDR 7.4 are produced according to customer order

* Future Products

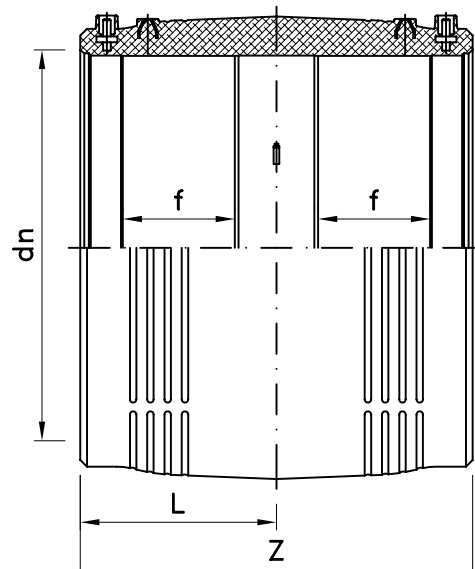
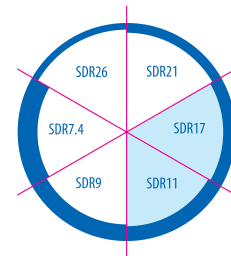

**Special Fittings
Collector**



**We are able to produce special fittings like collectors, concentric Reducer etc;
according to customer order, technical and schematics.**



- **Islamabad :**

UAN : (92-51) 111 000 789, 4861034-7, Fax : (92-51) 4861033
E-mail : islamabad@dadex.com.pk

- **Lahore :**

UAN : (92-42) 111 000 789, 35760735-6, Fax : (92-42) 35760734
E-mail : lahore@dadex.com.pk

- **Multan :**

Tel : (92-61) 4545259, Fax : (92-61) 4784688
E-mail : multan@dadex.com.pk

- **Faisalabad :**

Tel : (92-41) 8861981, 8787944, Fax : (92-41) 8787944
E-mail : faisalabad@dadex.com.pk

- **Peshawar :**

Tel : (92-91) 5840316-7, Fax : (92-91) 5840317
E-mail : peshawar@dadex.com.pk

- **Quetta :**

Tel : (92-333 7845732)
E-mail: quetta@dadex.com.pk

For Technical information and assistance, please contact Dadex Techno Commercial Department on 111 000 789 or contact Dadex Sales Office near you.

Note : All information contained in this literature is given in good faith. The user should, however, check that the product is suitable for purpose, in the application for which it shall be used. Please ensure compliance with all health and safety requirements. Whilst continuing its programme of continuous development, Seller reserves the right to modify or extend any published information without any prior notification. No responsibility can be accepted for any error, omissions or incorrect assumptions.

"Seller's Responsibility: responsibility of seller ceases once the goods are delivered to the buyer's representative at our factory, where delivery is taken in person. In other cases responsibility of seller shall cease once the goods are delivered to the buyer's/carrier's authorized representative (s). No claims of any type including in-transit loss, damage, pilferage, short-delivery, etc. will be entertained by the seller and the buyer agrees to hold the seller harmless in this regard. Additionally, seller shall not be responsible for any consequential damages including, but not limited to, economic loss of any kind whatsoever, upon the products being delivered to the seller as per the terms of this Clause. Any claim or responsibility as stated herein will not be entertained by the seller and such action will also not be the cause of dispute by the buyer".

DADEX Eternit Limited

Dadex House : 34-A/1, Block-6, P.E.C.H.S, Shahrah-e-Faisal, Karachi, Pakistan.

Tel. # (92-21) 111 000 789, Fax # (92-21) 34313881, 34315716

E-mail : info@dadex.com.pk Web : www.dadex.com www.facebook.com/dadexpk/